



The Chemical Company

MASTERFLOW[®] 885

High Strength Metallic Aggregate Reinforced Non-Shrink, Non Catalysed Grout With Load Bearing Properties

Description of Product

MASTERFLOW[®] 885 is a ready to use product in powder form, which requires only the on-site addition of water to produce a non-shrink, metallic reinforced grout. Use of specially processed malleable metallic aggregate improves impact and dynamic loading resistance compared with normal cementitious grouts.

Fields of Application

MASTERFLOW[®] 885 is formulated for use at any consistency from fluid to damp-pack, and may be used with confidence for grouting and precision bearing operations where shrinkage must be eliminated to achieve full bedding and load transfer.

- Rail tracks, crane rails.
- Turbines, generators and compressors.
- Rolling, stamping, drawing and finishing mills.
- Paper machine soleplates.
- Anchor bolts and rods.
- For all heavy duty grouting applications.

Features and Benefits

- Meets the compressive strength and non-shrink requirements of CRD-C 621, Corps of Engineers Specification for Non-shrink Grout.
- Hardens free of bleeding, settlement or drying shrinkage when mixed, placed and cured at any consistency - fluid, flowable, plastic or damp pack.
- Can be used at temperatures ranging from as high as 40°C to as low as 4°C when mixing and placing recommendations are followed.
- Designed for use where thermal movement of equipment and machinery and other effects of heating/cooling and wetting/drying are anticipated.
- Contains both metallic and quartz aggregates to provide high strengths and increased impact resistance under dynamic and repetitive loading.
- Can be applied in thicknesses from 10mm to 100mm.

Typical Properties/ Technical Data

Plastic Density	2300 kg/m ³		
Typical compressive strengths @ 20°C			
Consistency			
	Fluid (1)	Flowable (2)	Plastic (3)
	N/mm ²	N/mm ²	N/mm ²
1 day	20	30	49
3 days	35	40	64
7 days	60	50	71
28 days	60	72	82
(1)	30 seconds flow by Corps of Engineers Flow Cone method.		
(2)	400mm flow after 1 minute by Colcrete flow trough.		
(3)	90% flow on flow table, ASTM C-230,5 drops in 3 seconds.		

Note

The data shown is based on controlled laboratory tests. Reasonable variations from the results shown can be expected. Field and laboratory tests should be controlled on the basis of the desired placing consistency rather than strictly on the water content.

Application Procedure

Preparation of Substrate

The substrate onto which the grout is to be applied should be mechanically prepared to remove laitance and expose aggregate. The substrate must be sound and free of oil, dust, dirt, paint, curing compounds and other contaminants. Soak area to be grouted with water for a minimum of 3 hours prior to grouting to minimise localised absorption and to assist in the free flow of the grout. Substrates should be damp but free of standing water. Particular attention should be paid to bolt holes to ensure that these are water-free. Use vacuum and/or oil free compressed air to remove free standing water.

Base plates, bolts, etc. must be clean and free of oil, grease, paint and other contaminants. Set and align equipment. If shims are to be removed after the grout has set, then lightly grease them for easy removal.

Formwork

Ensure formwork is secure and watertight to prevent movement and leaking during the placing and curing of the grout. The area should be free of excessive vibration. Shut down adjacent machinery until the grout has hardened. Formwork should be designed to allow a hydrostatic head of 150mm to be maintained throughout. On the side where the grout is to be poured, allow 150mm clearance between the sides of the form and the base plate of the machine.

On the opposite side allow at least 50-100mm for the head of the grout and 50mm clearance between the formwork and the edge of the base plate

Mixing:

For optimum results a high shear paddle or vane mixer should be used. Colloidal impeller mixers are not suitable for use with this product. Air entrainment should be avoided.

For large or continuous placement ensure that adequate mixing capacity and sufficient labour is available. A holding tank fitted with agitation may be required.

Add the correct amount of water for the required consistency to the mixer and then add the complete pack(s) slowly while mixing. Mix for 3-5 minutes depending upon mixer, until a smooth, uniform, lump free consistency is achieved.

The following indicates the appropriate quantity of water required to mix a 25Kg bag of MASTERFLOW® 885 grout to various consistencies at the temperature shown.

Water demand (litres per 25Kg bag)				
Consistency	Fluid	Flowable	Plastic	Damp Pack
Temperature 20°C	4.6	4.2	3.6	3.4

A trial mix may be required to establish the correct water content, which will depend upon mixing equipment and site temperatures.

Application Underplate:

Ensure sufficient material is available to complete the work and obtain a continuous fill.

Fill all the bolt pockets with grout before pouring the rest of the underplate grout. Pour the grout continuously from one side only to avoid air entrapment. Maintain a constant hydrostatic head of approximately 150mm, to promote flow. DO NOT vibrate. Lengths of metal or plastic strapping laid in the formwork prior to placing can be used to aid complete filling.

Grouting large volumes:

Where the thickness of grout exceeds 100 mm the addition of clean, graded 10mm aggregates at up to one to one by weight is recommended. In this instance normal concrete mixers and pumps may be used.

Pumping:

MASTERFLOW® 885 may be placed using piston, ram or diaphragm type grout pumps fitted with ball valves.

Placing techniques:

Diagram (A) illustrates typical placement of MASTERFLOW® 885 in the flowable state utilising straight pouring or pumping techniques to place a bedding mortar under bearing plates. Note that unrestrained areas around baseplates should always be kept to a minimum.

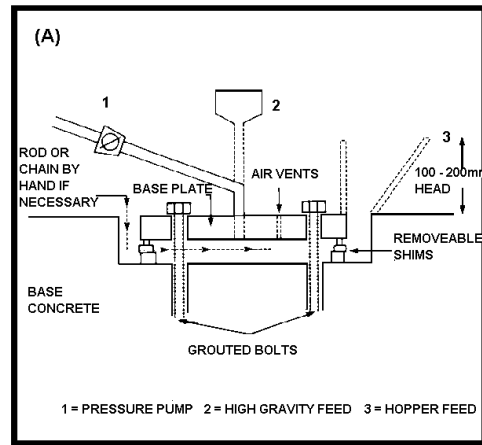

Unrestrained areas

Even with good curing, unrestrained areas of grout, for example around baseplates, may exhibit drying shrinkage cracking some time after placement. This is not detrimental to the performance of the grout where it is restrained under the plate or bearing, but may affect the cosmetic appearance of the application.

Curing

Good curing is essential on all exposed surfaces particularly in dry, sunny conditions. Failure to do so will reduce bond, strength and durability. Immediately after finishing apply 1 coat of MASTERKURE® 191 or 181 to all exposed surfaces. Alternative methods are water ponding, mist spraying and the like, but in all cases these must be maintained for at least 7 days. Keep the grout above 5°C at all times during application and cure.

Caution

Contact BASF Construction Chemicals (UK) Ltd for information on other products suitable for use in grouting prestressed and post tensioned cables and rods designed for stresses in excess of 550 N/mm².



The Chemical Company

Yield

Approximate yield (litres per 25kg bag)				
Consistency	Fluid	Flowable	Plastic	Damp Pack
Temperature 20°C	12.9	12.7	12.4	12.3

At fluid consistency approximately 78 bags per m³.
When estimating due allowance for wastage must be made.

Packaging

MASTERFLOW[®] 885 is available in 25 kg bags.

Storage

Store in cool dry conditions away from direct sunlight and at ambient temperatures.

Shelf Life

Up to 1 year when stored in unopened containers depending upon storage conditions.
Refer also to best before date.

BASF Construction Chemicals (UK) Ltd,
Albany House,
Swinton Hall Road Swinton,
Manchester M27 4DT
Tel: +44 (0) 161 794 7411
Fax +44 (0) 161 727 8547
www.basf-cc.co.uk

MASTERFLOW[®] 885 BASF Construction Chemicals UK Ltd Version 9 – July 2007

Health and Safety

*For full information on Health and Safety matters regarding this product the relevant Health and Safety Data Sheet should be consulted.

The following general comments apply to all products.

As with all chemical products, care should be taken during use and storage to avoid contact with eyes, mouth, skin and foodstuffs, (which may also be tainted with vapour until the product is fully cured and dried). Treat splashes to eyes and skin immediately. If accidentally ingested, seek medical attention. Keep away from children and animals. Reseal containers after use.

Powder Products

Should be handled to minimise dust formation; use light mask if excessive dust unavoidable. Cement powders when wet or moistened can cause burns to skin and eyes which should be protected during use.

Spillage

Chemical products can cause damage; clean spillage immediately.

Disclaimer:

This information and all further technical advice is based on our present knowledge and experience. However, it implies no liability or other legal responsibility on our part, including with regard to existing third party intellectual property rights, especially patent rights. In particular, no warranty, whether express or implied, or guarantee of product properties in the legal sense is intended or implied. We reserve the right to make any changes according to technological progress or further developments. The customer is not released from the obligation to conduct careful inspection and testing of incoming goods. Performance of the product described herein should be verified by testing, which should be carried out only by qualified experts in the sole responsibility of a customer. Reference to trade names used by other companies is neither a recommendation, nor does it imply that similar products could not be used.