

Famguard GS100

constructive solutions

Bridge deck waterproofing membrane

Uses

Protective waterproofing on:

- Bridge decks
- Elevated roadways
- Car park decks
- Access ramps

Advantages

- Waterproof
- Damage and puncture resistant
- Single layer application requires no additional protection
- Flexible, allowing conformity to surface contours
- Easy and quick to apply
- Hot-bonded for a watertight seal
- Remains stable without creeping or cracking
- Selvege for uniform edge laps
- Mineral surface provides excellent bond with sand asphalt carpet

Description

Famguard GS100 is a hot-applied pour and roll sheet membrane consisting of a 3 mm thick fully bonded water impermeable layer with green slate granule surface finish. All edge and end laps are also fully bonded. Famguard GS100 incorporates a high tensile polyester fabric, impregnated and coated with blended oxidised bitumen.

The high strength and robust nature of Famguard GS100 provide excellent resistance to puncture and damage.

Specification clauses

The Waterproofing membrane, where shown on the drawing, shall be Famguard GS100 obtained from Fosroc.

The waterproofing membrane shall be 3 mm thick, incorporating 330 g/m² polyester reinforcement, green slate granule surface finish and 100 mm selvedge. The membrane shall be laid in accordance with Fosroc's current technical data sheet

Properties

Thickness:	3 mm minimum
Flash point:	Over 65°C

Minimum installation

temperature:	+4°C rising
Strip tensile strength:	850N average
Elongation at break:	35%

Maintenance

There are no special requirements. Should any damage occur, repairs can be carried out by applying a cover patch set in hot bitumen, allowing a minimum of 150 mm overlap on all sides.

Should blisters occur, they shall be star cut, the loose membrane bonded to the substrate and a cover patch applied as above.

Application instructions

Surface preparation

The concrete must be frost free, dry and free from dust, laitance, dirt, oil and other foreign matter. The use of concrete curing compounds may impair adhesion. Where a curing compound has been used a site adhesion trial of the Famguard GS100 system is recommended to confirm compatibility.

Priming

All surfaces to which the membrane is to be applied must be fully primed with Proofex Primer. Apply the primer by brush or broom, avoiding ponding and ensuring complete coverage. When the primed surface is dry Famguard GS100 can be laid.

Laying

Famguard GS100 should be laid by the conventional pour and roll technique, using hot melt bitumen compound. Fully bonded lap joints should be 100 mm along the roll edges, using the 100 mm selvedge as a guide, and 150 mm minimum overlap at roll ends or other transverse joints. During application it is preferable that the hot melt bitumen compound extruded along the roll edge is kept to a minimum.

Famguard GS100 does not require the use of a protective layer or tack coat prior to the application of the sand asphalt carpet or other surface finishes. However, it is recommended that heavy trafficking of the waterproof membrane is prohibited. The sand asphalt carpet or other surface finishes shall be applied as soon as the Famguard GS100 has cooled to ambient temperature. Although the membrane can be left exposed without losing flexibility or efficiency it is desirable that the sand

Famguard GS100

asphalt carpet is laid as soon as possible to minimise the risk of blistering.

Example of treatment of trafficked surface areas is shown below

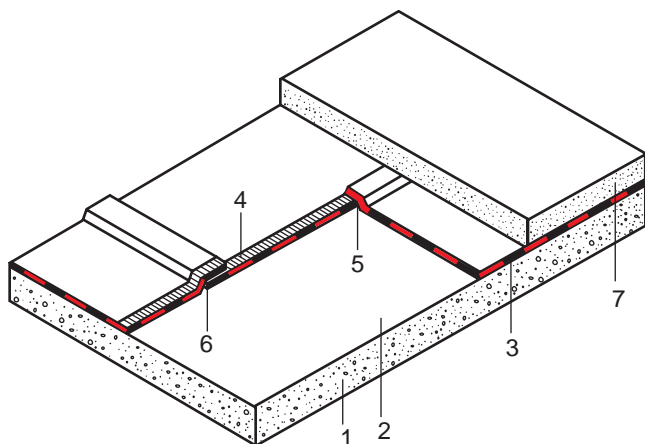

- 1 Concrete bridge deck
- 2 Concrete primed with Proofex Primer
- 3 Famguard GS100 set in hot bitumen compound
- 4 100 mm selvedge
- 5 Edge lap joint 100 mm
- 6 End lap joint 150 mm
- 7 Surfacing layers

Application to non-trafficked surfaces

Famguard GS100, being flexible, is suitable for the waterproofing treatment of non-trafficked surfaces where sharp directional changes occur, e.g. angles to parapets and abutments, through service ducts, gullies, and on vertical surfaces.

End overlaps across sections, through ducts etc. should provide 150 mm cover and adjacent sheet along the section edge should provide a 100 mm lap utilising the selvedge.

When the membrane is continued up parapets or other vertical faces it is recommended that it is bonded into a 30 x 30 mm chase and sealed with Plastiseal rubber bitumen sealing compound.

Note: All concrete, brickwork, etc. to which Famguard GS100 is to be applied must be primed with Proofex Primer.

Examples of treatment of non-trafficked surface areas are shown below:

Parapets

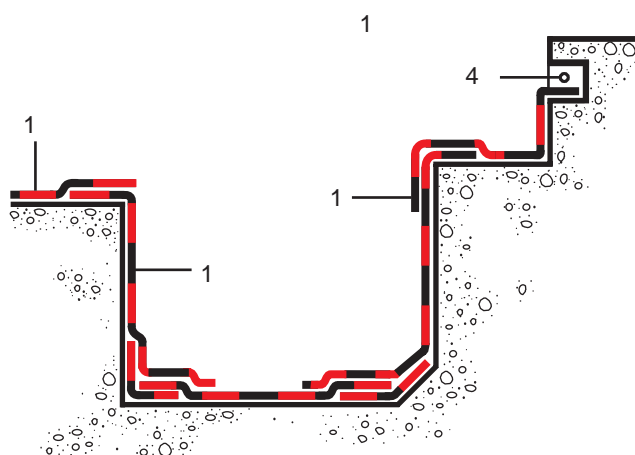
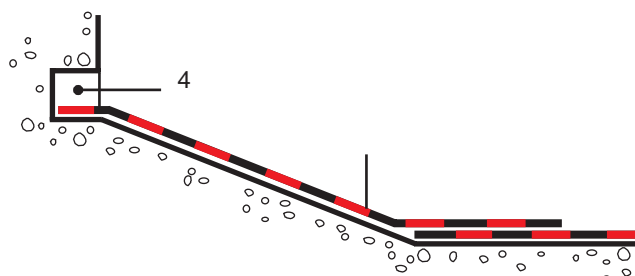
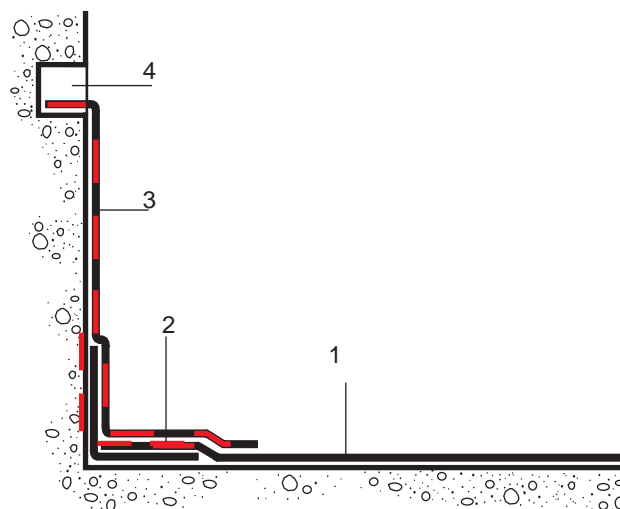

- 1 Famguard GS100 set in hot bitumen compound
- 2 200 mm reinforcing strip of Famguard GS100 set in hot bitumen compound
- 3 Famguard GS100 set in hot bitumen compound lap joint to horizontal 150 mm minimum
- 4 *Plastiseal pointing

* Also available from Fosroc.

Famguard GS100

Estimating

Roll width:	1 m nominal
Roll length:	8 m nominal
Roll weight:	38 kg nominal
Side lap:	100 mm
End lap:	150 mm

Storage

Storage conditions

Store vertically in original unopened packaging, in cool dry conditions, away from sunlight.

Proofex Primer must be stored in accordance with the Highly Flammable Liquids and Liquefied Gases Regulations 1972.

Precautions

Health and safety

There are no known health hazards associated with Famguard GS100 in normal use.

For further information about Proofex Primer see relevant Product Safety Data Sheet.

Additional information

Technical data:	Proofex Primer
Flash point:	32°C
Density:	0.9 kg/litre
Storage life:	2 years
Coverage:	6 to 8 m ² /litre
Minimum installation temperature:	+4°C rising
Drying time:	1 to 2 hours
Pack size:	25 ltr drums



Fosroc Limited
Drayton Manor Business Park
Coleshill Road, Tamworth,
Staffordshire B78 3TL. UK

www.fosroc.com

Important note

Fosroc products are guaranteed against defective materials and manufacture and are sold subject to its standard Conditions for the Supply of Goods and Services, copies of which may be obtained on request. Whilst Fosroc endeavours to ensure that any advice, recommendation, specification of information it may give is accurate and correct, it cannot, because it has no direct or continuous control over where or how its products are applied, accept any liability either directly or indirectly arising from the use of its products, whether or not in accordance with any advice, specification, recommendation of information given by it.

Famguard is the trade mark of Fosroc International Limited

telephone:
+44 (0) 1827 262222

fax:
+44 (0) 1827 262444

email:
uk@fosroc.com



Certificate number FM 610